

CBSE AIPMT - 2005

Prelims Question Paper

Physics

1. A coil in the shape of an equilateral triangle of side l is suspended between the pole pieces of a permanent magnet such that it is in plane of the coil. If due to a current i in the triangle a torque τ acts on it, the side l of the triangle is :

- 1) $(2/\sqrt{3}) (\tau/Bi)^{1/2}$
- 2) $(2/\sqrt{3}) (\tau/Bi)$
- 3) $2(\tau / \sqrt{3} Bi)^{1/2}$
- 4) $(1/\sqrt{3}) (\tau/Bi)$

2. Two batteries, one of emf 18 V and internal resistance 2Ω and the other of emf 12 V and internal resistance 1Ω , are connected as shown. The voltmeter V will record a reading of :

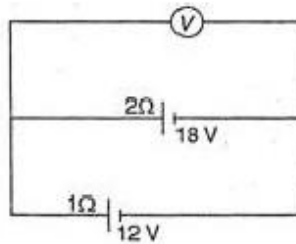

- 1) 7 V
 - 2) 21 V
 - 3) 14 V
 - 4) 28 V
3. A point source emits sound equally in all directions in a non-absorbing medium. Two points P and Q are at distance of 2m and 3m respectively from the source. The ratio of the intensities of the waves at P and Q is :
- 1) 9 : 4
 - 2) 2 : 9
 - 3) 9 : 2
 - 4) 4 : 9
4. A bomb of mass 30 kg at rest explodes into two pieces of masses 18 kg and 12 kg. The velocity of 18 kg mass is 6 ms^{-1} . The kinetic energy of the other mass is :
- 1) 243 J
 - 2) 486 J
 - 3) 564 J
 - 4) 388 J

5. A drum of radius R and mass M , rolls down without slipping along an inclined plane of angle θ . The frictional force :
- 1) converts translational energy to rotational energy
 - 2) dissipates energy as heat
 - 3) decreases the rotational motion
 - 4) decreases the rotational and translational motion
6. Imagine a new planet having the same density as that of earth but it is 3 times bigger than the earth in size. If the acceleration due to gravity on the surface of earth is g and that on the surface of the new planet is g' , then :
- 1) $g' = 3g$
 - 2) $g' = g/9$
 - 3) $g' = 9g$
 - 4) $g' = g/3$
7. A network of four capacitors of capacity equal to $C_1 = C$, $C_2 = 2C$, $C_3 = 3C$ and $C_4 = 4C$ are connected to a battery as shown in the figure. The ratio of the charges on C_2 and C_4 is :

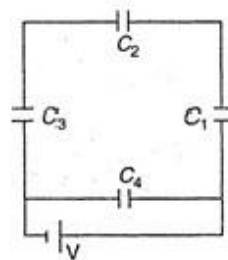

- 1) $22/3$
 - 2) $3/22$
 - 3) $7/22$
 - 4) $22/7$
8. Which of the following circular rods, (given radius r and length l) each made of the same material and whose ends are maintained at the same temperature will conduct most heat ?
- 1) $r = 2r_0$; $l = 2l_0$
 - 2) $r = 2r_0$; $l = l_0$
 - 3) $r = r_0$; $l = l_0$
 - 4) $r = r_0$; $l = 2l_0$
9. In the reaction ${}^2_1\text{H} + {}^3_1\text{H} \rightarrow {}^4_2\text{He} + {}^1_0\text{n}$, if the binding energies of ${}^2_1\text{H}$, ${}^3_1\text{H}$ and ${}^4_2\text{He}$ are respectively a , b and c (in MeV), then the energy (in MeV) released in this reaction is :
- 1) $c + a - b$
 - 2) $c - a - b$
 - 3) $a + b + c$

4) $a + b - c$

10. A very long straight wire carries a current I . At the instant when a charge $+Q$ at point P has velocity \vec{v} as shown, the force on the charge is :

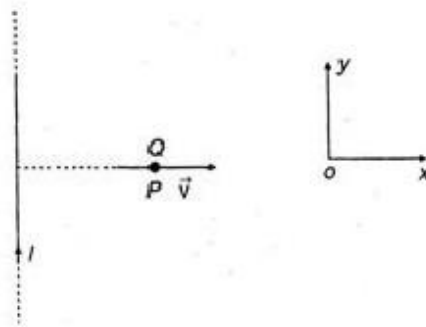

- 1) opposite to ox
 2) along ox
 3) opposite to oy
 4) along oy
11. Energy levels A, B and C of a certain atom correspond to increasing values of energy i.e., $E_A < E_B < E_C$. If λ_1 , λ_2 and λ_3 are wavelengths of radiations corresponding to transitions C to B, B to A and C to A respectively, which of the following relations is correct ?
- 1) $\lambda_3 = \lambda_1 + \lambda_2$
 2) $\lambda_3 = (\lambda_1 \lambda_2) / (\lambda_1 + \lambda_2)$
 3) $\lambda_1 + \lambda_2 + \lambda_3 = 0$
 4) $\lambda_{23} = \lambda_{21} + \lambda_{12}$
12. The work functions for metals A, B and C are respectively 1.92 eV, 2.0 eV and 5 eV. According to Einstein's equation, the metals which will emit photoelectrons for a radiation of wavelength 4100 Å is/are :
- 1) none
 2) A only
 3) A and B only
 4) all the three metals
13. The nuclei of which one of the following pairs of nuclei are isotones ?
- 1) $^{34}_{16}\text{Se}^{74}$, $^{31}_{15}\text{Ga}^{71}$
 2) $^{42}_{24}\text{Mo}^{92}$, $^{40}_{20}\text{Zr}^{92}$
 3) $^{38}_{38}\text{Sr}^{84}$, $^{38}_{38}\text{Sr}^{86}$
 4) $^{20}_{20}\text{Ca}^{40}$, $^{16}_{16}\text{S}^{32}$
14. As per this diagram a point charge $+q$ is placed at the origin O. Work done in taking another point charge $-Q$ from the point A [co-ordinates (0, a)] to another point B [co-ordinates (a, 0)] along the straight path AB is :

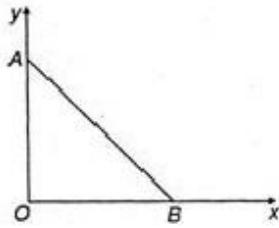

- 1) zero
- 2) $((-qQ/4\pi\epsilon_0)(1/a^2)) \sqrt{2}a$
- 3) $((qQ/4\pi\epsilon_0)(1/a^2)) \cdot a\sqrt{2}$
- 4) $((qQ/4\pi\epsilon_0)(1/a^2)) \sqrt{2}a$

15. As a result of change in the magnetic flux linked to the closed loop shown in the figure, an emf V volt is induced in the loop. The work done (joules) in taking a charge Q coulomb once along the loop is :

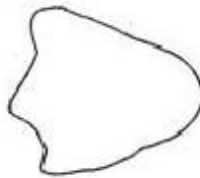

- 1) QV
- 2) zero
- 3) $2QV$
- 4) $QV/2$

16. For the network shown in the figure, the value of the current i is :

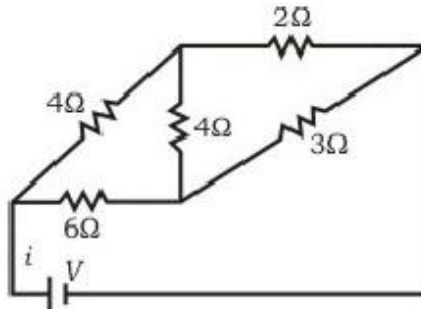

- 1) $9V/7$
- 2) $5V/18$
- 3) $9V/7$
- 4) $18V/5$

17. The circular motion of a particle with constant speed is :

- 1) simple harmonic but not periodic
- 2) periodic and simple harmonic
- 3) neither periodic nor simple harmonic
- 4) periodic but not simple harmonic

18. A particle executing simple harmonic motion of amplitude 5 cm has maximum speed of 31.4 cm/s. The frequency of its oscillation is :

- 1) 2 Hz
- 2) 1.5 Hz

3) 0.5 Hz

4) 1 Hz

19. The ratio of the dimensions of Planck's constant and that of the moment of inertia is the dimension of :

1) frequency

2) velocity

3) angular momentum

4) time

20. Which of the following processes is reversible ?

1) Transfer of heat by radiation

2) Electrical heating of a nichrome wire

3) Transfer of heat by conduction

4) Isothermal compression

21. The temperature of inversion of a thermocouple is 620°C and the neutral temperature is 300°C . what is the temperature of cold junction ?

1) 20°C

2) 120°C

3) -20°C

4) -120°C

22. A photosensitive metallic surface has work function, $h\nu_0$. If photons of energy $2h\nu_0$ fall on this surface, the electrons come out with a maximum velocity of $4 \times 10^6 \text{ m/s}$. When the photon energy is increased to $5h\nu_0$, then maximum velocity of photoelectrons will be :

1) $16 \times 10^6 \text{ m/s}$

2) $8 \times 10^7 \text{ m/s}$

3) $4 \times 10^5 \text{ m/s}$

4) $8 \times 10^6 \text{ m/s}$

23. Fission of nuclei is possible because the binding energy per nucleon in them :

1) increases with mass number at high mass numbers

2) decreases with mass number at high mass numbers

3) increases with mass number at low mass numbers

4) decreases with mass number at low mass numbers

24. Application of a forward bias to a p-n junction :

1) increases the number of donors on the n-side

2) increases the electric field in the depletion zone

3) increases the potential difference across the depletion zone

4) widens the depletion zone

25. The displacement x of a particle varies with time t as $x = ae^{-\alpha t} + be^{\beta t}$, where a , b , α and β are positive constants. The velocity of the particle will :

- 1) go on decreasing with time
- 2) be independent of α and β
- 3) drop to zero when $\alpha = \beta$
- 4) go on increasing with time

26. Two charges q_1 and q_2 are placed 30 cm apart, as shown in the figure. A third charge q_3 is moved along the arc of a circle of radius 40 cm from C to D. The change in the potential energy of the system is $(q_3/4\pi\epsilon_0)k$, where k is :

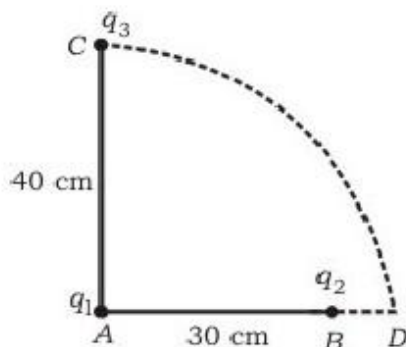

- 1) $8q_2$
- 2) $8q_1$
- 3) $4q_2$
- 4) $4q_1$

27. In any fission process the ratio (mass of fission products/mass of parent nucleus) is :

- 1) less than 1
- 2) greater than 1
- 3) equal to 1
- 4) depends on the mass of parent nucleus

28. An ideal gas heat engine operates in Carnot cycle between 227°C and 127°C . It absorbs 6×10^4 cal of heat at higher temperature. Amount of heat converted to work is :

- 1) 2.4×10^4 cal
- 2) 3.6×10^4 cal
- 3) 1.2×10^4 cal
- 4) 6.4×10^4 cal

29. If a vector $2\hat{i} + 3\hat{j} + 8\hat{k}$ is perpendicular to the vector $4\hat{j} - 4\hat{i} + \alpha\hat{k}$, then the value of α is :

- 1) -2
- 2) 1/2

3) $-(1/2)$

4) 2

30. Zener diode is used for :

1) producing oscillations in an oscillator

2) amplification

3) stabilisation

4) rectification

31. A force F acting on an object varies with distance x as shown here. The force is in N and x is in m. The work done by the force in moving the object from $x = 0$ to $x = 6$ m is :

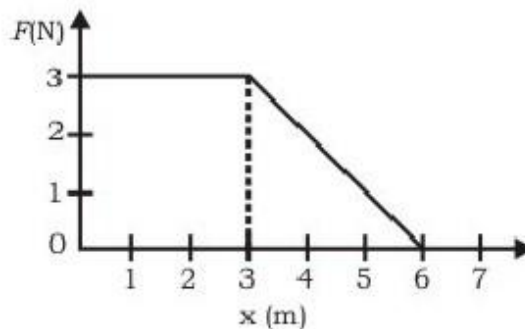

1) 10.5 J

2) 13.5 J

3) 8.5 J

4) 6.5 J

32. A stone tied to the end of a string of 1 m long is whirled in a horizontal circle with a constant speed. If the stone makes 22 revolutions in 44 s, what is the magnitude and direction of acceleration of the stone ?

1) $(\pi^2/4)$ ms⁻² and direction along the radius towards the centre

2) $2\pi^2$ ms⁻² and direction along the radius away from centre

3) π^2 ms⁻² and direction along the radius towards the centre

4) $4\pi^2$ ms⁻² and direction along the tangent to the circle

33. If the magnetic dipole moment of an atom of diamagnetic material, paramagnetic material and ferromagnetic material are denoted by μ_d , μ_p and μ_f respectively, then :

1) $\mu_d \neq 0$ and $\mu_f \neq 0$

2) $\mu_p = 0$ and $\mu_f \neq 0$

3) $\mu_d = 0$ and $\mu_p \neq 0$

4) $\mu_d \neq 0$ and $\mu_p = 0$

34. In a circuit, L, C and R are connected in series with an alternating voltage source of frequency f . The current leads the voltage by 45° . The value of C is :

1) $(1)/(2\pi f(2\pi fL + R))$

- 2) $(1)/(\pi f(2\pi fL + R))$
- 3) $(1)/(2\pi f(2\pi fL - R))$
- 4) $(1)/(\pi f(2\pi fL - R))$

35. The angular resolution of a 10 cm diameter telescope at a wavelength of 5000 Å is of the order of :

- 1) 10^6 rad
- 2) 10^{-4} rad
- 3) 10^4 rad
- 4) 10^{-6} rad

36. Two vibrating tuning forks produce progressive waves given by $y_1 = 4 \sin 500 \pi t$ and $y_2 = 2 \sin 506 \pi t$. Number of beats produced per minute is :

- 1) 360
- 2) 180
- 3) 120
- 4) 30

37. When a wire of uniform cross-section a , length l and resistance R is bent into a complete circle, resistance between two of diametrically opposite points will be :

- 1) $R/4$
- 2) $2R$
- 3) $4R$
- 4) $R/2$

38. Carbon, silicon and germanium atoms have four valence electrons each. Their valence and conduction bands are separated by energy band gaps represented by $(E_g)_C$, $(E_g)_{Si}$ and $(E_g)_{Ge}$ respectively. Which one of the following relationships is true in their case ?

- 1) $(E_g)_C > (E_g)_{Si}$
- 2) $(E_g)_C = (E_g)_{Si}$
- 3) $(E_g)_C < (E_g)_{Ge}$
- 4) $(E_g)_C < (E_g)_{Si}$

39. If λ_v , λ_x and λ_m represent the wavelengths of visible light, X-rays and microwaves respectively, then :

- 1) $\lambda_m > \lambda_x > \lambda_v$
- 2) $\lambda_v > \lambda_m > \lambda_x$
- 3) $\lambda_m > \lambda_v > \lambda_x$
- 4) $\lambda_v > \lambda_x > \lambda_m$

40. Two boys are standing at the ends A and B of a ground, where $AB = a$. The boy at B starts running in a direction perpendicular to AB with velocity v_1 . The boy at A starts running simultaneously with velocity v and catches the other boy in a time t , where t is :

- 1) $a/\sqrt{(v^2 + v_1^2)}$
- 2) $\sqrt{(a/v^2 - v_1^2)}$
- 3) $a/(v - v_1)$

4) $a/(v + v_1)$

41. A 5-A fuse wire can withstand a maximum power of 1 W in circuit. The resistance of the fuse wire is :

- 1) 0.02Ω
- 2) 0.2Ω
- 3) 0.4Ω
- 4) 0.04Ω

42. Two bodies have their moments of inertia I and $2I$ respectively about their axis of rotation. If their kinetic energies of rotation are equal, their angular momenta will be in the ratio :

- 1) $1 : 4$
- 2) $\sqrt{2} : 1$
- 3) $4 : 1$
- 4) $1 : \sqrt{2}$

43. An electron moves in a circular orbit with a uniform speed v . It produces a magnetic field B at the centre of the circle. The radius of the circle is proportional to :

- 1) B/v
- 2) v/B
- 3) $\sqrt{(v/B)}$
- 4) $\sqrt{(B/v)}$

44. Choose the only false statement from the following :

- 1) Substances with energy gap of the order of 10 eV are insulators
- 2) The conductivity of a semiconductor increases with increases in temperature
- 3) In conductors the valence and conduction bands may overlap
- 4) The resistivity of a semiconductor increases with increase in temperature

45. If the angle between the vectors \vec{A} and \vec{B} is θ , the value of the product $(\vec{B} \times \vec{A}) \cdot \vec{A}$ is equal to :

- 1) $BA^2 \cos^2 \theta$
- 2) $BA^2 \sin^2 \theta$
- 3) $BA^2 \sin \theta \cos \theta$
- 4) zero

46. The moment of inertia of a uniform circular disc of radius R and mass M about an axis passing from the edge of the disc and normal to the disc is :

- 1) $(5/2)MR^2$
- 2) MR^2
- 3) $(7/2)MR^2$

4) $(3/2)MR^2$

47. Copper has face-centered cubic (fcc) lattice with interatomic spacing equal to 2.54 Å. The value of lattice constant for this lattice is :

- 1) 2.29 Å
- 2) 3.29 Å
- 3) 2.59 Å
- 4) 3.59 Å

48. The total energy of an electron in the first excited state of hydrogen is about - 3.4 eV. Its kinetic energy in this state is :

- 1) - 3.4 eV
- 2) - 1.7 eV
- 3) 1.7 eV
- 4) 3.4 eV

49. For a satellite moving in an orbit around the earth, the ratio of kinetic energy to potential energy is :

- 1) 4
- 2) 1/2
- 3) $1/\sqrt{2}$
- 4) 1/4

50. A ball is thrown vertically upward. It has a speed of 10 m/s when it has reached one half of its maximum height. How high does the ball rise ? (Taking $g = 10 \text{ m/s}^2$)

- 1) 6 m
- 2) 10 m
- 3) 14 m
- 4) 18 m

Chemistry

51. Which amongst the following is the most stable carbocation ?

- 1) $\text{CH}_3-\overset{+}{\text{C}}-\text{H}$
|
 CH_3
- 2) CH_3
|
 $\text{CH}_3-\overset{+}{\text{C}}$
|
 CH_3
- 3) $\overset{+}{\text{CH}_3}$
- 4) $\text{CH}_3\overset{+}{\text{CH}_2}$

52. Products of the following reaction :

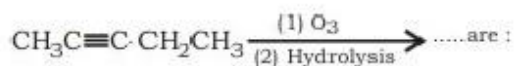

- 1) $\text{CH}_3\text{CHO} + \text{CH}_3\text{CH}_2\text{CHO}$
- 2) $\text{CH}_3\text{COOH} + \text{CH}_3\text{COCH}_3$
- 3) $\text{CH}_3\text{COOH} + \text{HOOC}\cdot\text{CH}_2\text{CH}_3$
- 4) $\text{CH}_3\text{COOH} + \text{CO}_2$

53. At 25°C , the dissociation constant of a base, BOH , is 1.0×10^{-12} . The concentration of hydroxyl ions in 0.01 M aqueous solution of the base would be :

- 1) $1.0 \times 10^{-6} \text{ mol L}^{-1}$
- 2) $1.0 \times 10^{-5} \text{ mol L}^{-1}$
- 3) $1.0 \times 10^{-8} \text{ mol L}^{-1}$
- 4) $1.0 \times 10^{-7} \text{ mol L}^{-1}$

54. Which one of the following pairs represents stereoisomerism ?

- 1) Chain isomerism and rotational isomerism
- 2) Structural isomerism and geometric isomerism
- 3) Linkage isomerism and geometric isomerism
- 4) Optical isomerism and geometric isomerism

55. Aniline in a set of reactions yielded a product D.

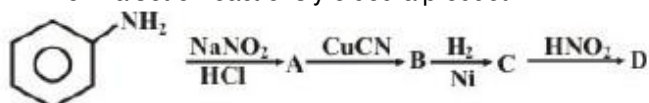

The structure of the product D would be :

- 1) $\text{C}_6\text{H}_5\text{CH}_2\text{NH}_2$
- 2) $\text{C}_6\text{H}_5\text{NHCH}_2\text{CH}_3$
- 3) $\text{C}_6\text{H}_5\text{NHOH}$
- 4) $\text{C}_6\text{H}_5\text{CH}_2\text{OH}$

56. The correct order in which the O — O bond length increases in the following is :

- 1) $\text{H}_2\text{O}_2 < \text{O}_2 < \text{O}_3$
- 2) $\text{O}_3 < \text{H}_2\text{O}_2 < \text{O}_2$
- 3) $\text{O}_2 < \text{O}_3 < \text{H}_2\text{O}_2$
- 4) $\text{O}_2 < \text{H}_2\text{O}_2 < \text{O}_3$

57. The mass of carbon anode consumed (giving only carbon dioxide) in the production of 270 kg of aluminium metal from bauxite by the Hall process is : (Atomic mass $\text{Al} = 27$)

- 1) 180 kg
- 2) 120 kg
- 3) 360 kg

4) 90 kg

58. In a set of reactions, acetic acid yielded a product D.

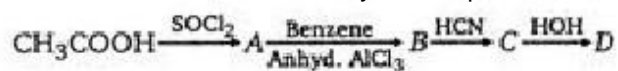

The structure of D would be :

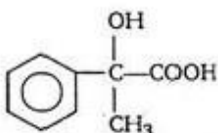
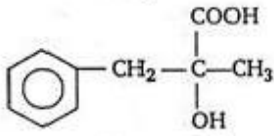
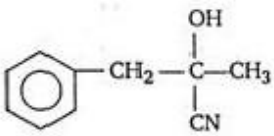
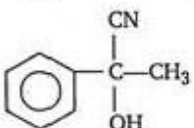
- 1) 
- 2) 
- 3) 
- 4) 

59. The cell membranes are mainly composed of :

- 1) carbohydrates
- 2) proteins
- 3) phospholipids
- 4) fats

60. The major organic product formed from the following reaction :

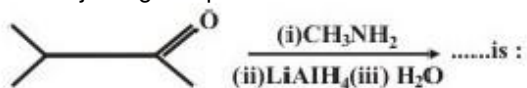

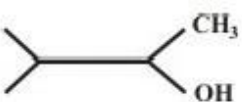
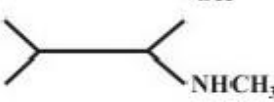
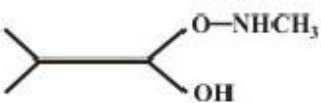
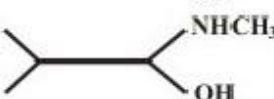
- 1) 
- 2) 
- 3) 
- 4) 

61. The number of moles of KMnO_4 reduced by one mole of KI in alkaline medium is :

- 1) one fifth
- 2) five
- 3) one

4) two

62. Which of the following molecules has trigonal planar geometry ?

- 1) IF₃
- 2) PCl₃
- 3) NH₃
- 4) BF₃

63. The aqueous solution containing which one of the following ions will be colourless ?
(Atomic no. : Sc = 21, Fe = 26, Ti = 22, Mn = 25)

- 1) Sc³⁺
- 2) Fe²⁺
- 3) Ti³⁺
- 4) Mn²⁺

64. Four successive members of the first row transition elements are listed below with their atomic numbers. Which one of them is expected to have the highest third ionization enthalpy ?

- 1) Vanadium (Z = 23)
- 2) Chromium (Z = 24)
- 3) Iron (Z = 26)
- 4) Manganese (Z = 25)

65. Which one of the following compounds is most acidic ?

1) Cl—CH₂—CH₂—OH

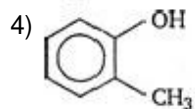
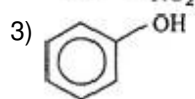
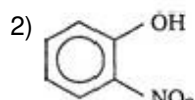

66. A reaction occurs spontaneously if :

- 1) $T\Delta S < \Delta H$ and both ΔH and ΔS are +ve
- 2) $T\Delta S > \Delta H$ and both ΔH and ΔS are +ve
- 3) $T\Delta S = \Delta H$ and both ΔH and ΔS are +ve
- 4) $T\Delta S > \Delta H$ and ΔH is +ve and ΔS is -ve

67. The monomer of the polymer :

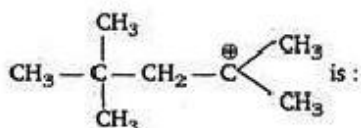

- 1) $\text{H}_2\text{C}=\overset{\text{CH}_3}{\text{C}} \begin{matrix} \text{CH}_3 \\ \text{CH}_3 \end{matrix}$
- 2) $(\text{CH}_3)_2\text{C}=\text{C}(\text{CH}_3)_2$
- 3) $\text{CH}_3\text{CH}=\text{CH}\cdot\text{CH}_3$
- 4) $\text{CH}_3\text{CH}=\text{CH}_2$

68. The correct sequence of increasing covalent character is represented by :

- 1) $\text{LiCl} < \text{NaCl} < \text{BeCl}_2$
- 2) $\text{BeCl}_2 < \text{NaCl} < \text{LiCl}$
- 3) $\text{NaCl} < \text{LiCl} < \text{BeCl}_2$
- 4) $\text{BeCl}_2 < \text{LiCl} < \text{NaCl}$

69. What is the correct relationship between the pHs of isomolar solutions of sodium oxide (pH1), sodium sulphide (pH2), sodium selenide (pH3) and sodium telluride (pH4) ?

- 1) $\text{pH}_1 > \text{pH}_2 \approx \text{pH}_3 > \text{pH}_4$
- 2) $\text{pH}_1 < \text{pH}_2 < \text{pH}_3 < \text{pH}_4$
- 3) $\text{pH}_1 < \text{pH}_2 < \text{pH}_3 \approx \text{pH}_4$
- 4) $\text{pH}_1 > \text{pH}_2 > \text{pH}_3 > \text{pH}_4$

70. Which of the following pairs of a chemical reaction is certain to result in a spontaneous reaction ?

- 1) Exothermic and decreasing disorder
- 2) Endothermic and increasing disorder
- 3) Exothermic and increasing disorder
- 4) Endothermic and decreasing disorder

71. The vapour pressure of two liquids P and Q are 80 and 60 torr, respectively. The total vapour pressure of solution obtained by mixing 3 moles of P and 2 moles of Q would be :

- 1) 144 torr
- 2) 288 torr
- 3) 14 torr
- 4) 72 torr

72. Which one of the following alkenes will react faster with H_2 under catalytic hydrogenation conditions ?

(R = Alkyl substituent)

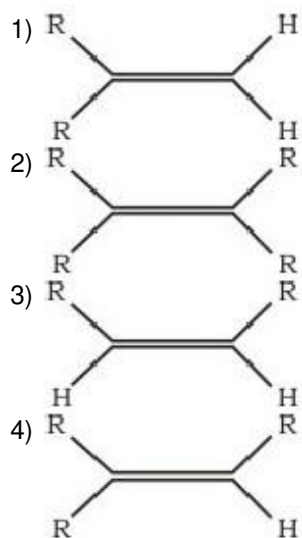

73. For a first order reaction $A \rightarrow B$, the reaction rate at reactant concentration of 0.01 M is found to be $2.0 \times 10^{-5} \text{ mol L}^{-1} \text{ s}^{-1}$. The half life period of the reaction is :

- 1) 227 s
- 2) 327 s
- 3) 527 s
- 4) 347 s

74. Which of the following is the electron deficient molecule ?

- 1) B_2H_6
- 2) C_2H_6
- 3) PH_3
- 4) SiH_4

75. A nuclide of an alkaline earth metal undergoes radioactive decay by emission of three particles in succession. The group of the periodic table to which the resulting daughter element would belong is :

α -

- 1) Group 14
- 2) Group 16
- 3) Group 4
- 4) Group 6

76. The surface tension of which of the following liquid is maximum ?

- 1) H_2O
- 2) C_6H_6
- 3) CH_3OH
- 4) C_2H_5OH

77. The absolute enthalpy of neutralisation of the reaction :

$\text{MgO(s)} + 2\text{HCl(aq)} \rightarrow \text{MgCl}_2\text{(aq)} + \text{H}_2\text{O(l)}$ will be :

- 1) less than - 57.33 kJ mol⁻¹
- 2) - 57.33 kJ mol⁻¹
- 3) greater than -57.33 kJ mol⁻¹
- 4) 57.33 kJ mol⁻¹

78. Which one of the following forms micelles in aqueous solution above certain concentration ?

- 1) Urea
- 2) Dodecyl trimethyl ammonium chloride
- 3) Pyridinium chloride
- 4) Glucose

79. Electrolytic reduction of nitrobenzene weakly acidic medium gives :

- 1) aniline
- 2) nitrosobenzene
- 3) N-phenylhydroxylamine
- 4) p-hydroxyaniline

80. Equilibrium constants K_1 and K_2 for the following equilibria :

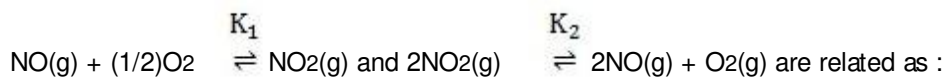

- 1) $K_2 = 1/K_1$
- 2) $K_2 = K_1$
- 3) $K_2 = K_1/2$
- 4) $K_2 = 1/K_1^2$

81. Which of the following would have a permanent dipole moment ?

- 1) BF_3
- 2) SiF_4
- 3) SF_4
- 4) XeF_4

82. Which of the following undergoes nucleophilic substitution exclusively by $\text{S}_{\text{N}}1$ mechanism?

- 1) Benzyl chloride
- 2) Ethyl chloride
- 3) Chlorobenzene
- 4) Isopropyl chloride

83. The rate of reaction between two reactants A and B decreases by a factor of 4, if the

concentration of reactant B is doubled. The order of this reaction with respect to reactant B is :

- 1) -1 2) -2 3) 1 4) 2

84. In a face-centered cubic lattice, a unit cell is shared equally by how many unit cells ?

- 1) 8 2) 4 3) 2 4) 6

85. A solution of urea (mol. mass 56g mol^{-1}) boils at 100.18°C at the atmospheric pressure. If k_f and k_b for water are 1.86 and $0.512\text{K kg mol}^{-1}$ respectively, the above solution will freeze at :

- 1) -6.54°C
2) -65.4°C
3) 65.4°C
4) -0.654°C

86. Which functional group participates in disulphide bond formation in proteins ?

- 1) Thiolactone
2) Thiol
3) Thioether
4) Thioester

87. Which one of the following is an inner orbital complex as well as diamagnetic in behaviour ?

(Atomic no. : Zn = 30, Cr = 24, Co = 27, Ni = 28)

- 1) $[\text{Zn}(\text{NH}_3)_6]^{2+}$
2) $[\text{Cr}(\text{NH}_3)_6]^{3+}$
3) $[\text{Co}(\text{NH}_3)_6]^{3+}$
4) $[\text{Ni}(\text{NH}_3)_6]^{2+}$

88. The chirality of the compound

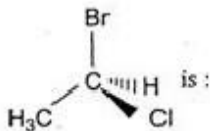

- 1) R 2) S 3) Z 4) E

89. H_2S gas when passed through a solution of cations containing HCl precipitates the cations of second group of qualitative analysis but not those belonging to the fourth group. It is because :

- 1) presence of HCl decreases the sulphide ion concentration
2) presence of HCl increases the sulphide ion concentration
3) solubility product of group II sulphides is more than that of group IV sulphides

4) sulphides of group IV cations are unstable in HCl

90. Which one of the following oxides is expected to exhibit paramagnetic behaviour ?

- 1) CO₂
- 2) SO₂
- 3) ClO₂
- 4) SiO₂

91. Which one of the following is expected to exhibit optical isomerism ?

(en = ethylenediamine)

- 1) cis-[Pt (NH₃)₂ Cl₂]
- 2) trans-[Co (en)₂ Cl₂]
- 3) trans-[Pt (NH₃)₂ Cl₂]
- 4) cis-[Co (en)₂ Cl₂]

92. The energy of second Bohr orbit of the hydrogen atom is -328 kJ mol⁻¹ ; hence the energy of fourth Bohr orbit would be :

- 1) - 41 kJ mol⁻¹
- 2) -1224 kJ mol⁻¹
- 3) -284 kJ mol⁻¹
- 4) -82 kJ mol⁻¹

93. The correct order of acid strength is :

- 1) HClO < HClO₂ < HClO₃ < HClO₄
- 2) HClO₄ < HClO < HClO₂ < HClO₃
- 3) HClO₂ < HClO₃ < HClO₄ < HClO
- 4) HClO₄ < HClO₃ < HClO₂ < HClO

94. The main reason for larger number of oxidation states exhibited by the actinides than the corresponding lanthanides, is :

- 1) lesser energy difference between 5f and 6d orbitals than between 4f and 5d orbitals
- 2) larger atomic size of actinides than the lanthanides
- 3) more energy difference between 5f and 6d orbitals than between 4f and 5d orbitals
- 4) greater reactive nature of the actinides than the lanthanides

95. Names of some compounds are given. Which one is not correct in IUPAC system ?

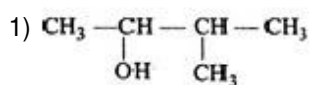

3-methyl-2 butanol

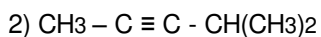

4-methyl-2-pentyne

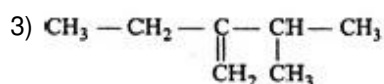

2-ethyl-3 methyl-but-1-ene

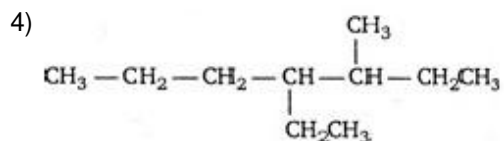

3-methyl-4 ethyl heptane

96. Which one of the following arrangements represents the correct order of electron gain enthalpy (with negative sign) of the given atomic species ?

- 1) $\text{Cl} < \text{F} < \text{S} < \text{O}$
- 2) $\text{O} < \text{S} < \text{F} < \text{Cl}$
- 3) $\text{S} < \text{O} < \text{Cl} < \text{F}$
- 4) $\text{F} < \text{Cl} < \text{O} < \text{S}$

97. A solution has a 1 : 4 mole ratio of pentane to hexane. The vapour pressure of the pure hydrocarbons at 20°C are 440 mm of Hg for pentane and 120 mm of Hg for hexane. The mole fraction of pentane in the vapour phase would be :

- 1) 0.178
- 2) 0.278
- 3) 0.378
- 4) 0.478

98. 4.5g of aluminium (at. mass 27 amu) is deposited at cathode from Al^{3+} solution by a certain quantity of electric charge. The volume of hydrogen produced at STP from H^+ ions in solution by the same quantity of electric charge will be :

- 1) 22.4 L
- 2) 32.8 L
- 3) 5.6 L
- 4) 11.2 L

99. The best method for the separation of naphthalene and benzoic acid from their mixture is :

- 1) chromatography
- 2) crystallisation
- 3) distillation
- 4) sublimation

100. The mole fraction of the solute in one molal aqueous solution is :

- 1) 0.054
- 2) 0.042
- 3) 0.018
- 4) 0.009

4) 0.009

Biology

101. The main organelle involved in modification and routing of newly synthesized proteins to their destinations is :
- 1) mitochondria
 - 2) endoplasmic reticulum
 - 3) lysosome
 - 4) chloroplast
102. There are two opposing views about origin of Modern man. According to one view Homo erectus in Asia were the ancestors of modern man. A study of variations of DNA however suggested African origin of Modern man. What kind of observation on DNA variation could suggest this ?
- 1) Greater variation in Africa than in Asia
 - 2) Variation only in Asia and no variation in Africa
 - 3) Greater variation in Asia than in Africa
 - 4) Similar variation in Africa and Asia
103. The world's highly prized wool yielding 'Pashmina' breed is :
- 1) sheep
 - 2) goat
 - 3) goat-sheep cross
 - 4) Kashmir sheep-Afghan sheep cross
104. Grey crescent is the area :
- 1) at the point of entry of sperm into ovum
 - 2) just opposite to the site of entry of sperm into ovum
 - 3) at the animal pole
 - 4) at the vegetal pole
105. Photosynthesis in C₄ plants is relatively less limited by atmospheric CO₂ levels because :
- 1) four carbon acids are the primary initial CO₂ fixation products
 - 2) the primary fixation of CO₂ is mediated via PEP carboxylase
 - 3) effective pumping of CO₂ into bundle sheath cells
 - 4) RUBISCO in C₄ plants has higher affinity for CO₂
106. At what stage of the cell cycle are histone proteins synthesized in a eukaryotic cell ?
- 1) During entire prophase
 - 2) During telophase
 - 3) During S-phase
 - 4) During G₂ stage of prophase

107. There exists a close association between the alga and the fungus within a lichen. The fungus :
- 1) fixes the atmospheric nitrogen for the alga
 - 2) provides protection, anchorage and absorption for the alga
 - 3) provides food for the alga
 - 4) releases oxygen for the alga
108. For retting of jute the fermenting microbe used is :
- 1) Helicobacter pylori
 - 2) Methophilic bacteria
 - 3) Streptococcus lactin
 - 4) Butyric acid bacteria
109. A student wishes to study the cell structure under a light microscope having 10X eyepiece and 45X objective. He should illuminate the object by which one of the following colours of light so as to get the best possible resolution ?
- 1) Yellow
 - 2) Green
 - 3) Blue
 - 4) Red
110. The net pressure gradient that causes the fluid to filter out of the glomeruli into the capsule is :
- 1) 20 mm Hg
 - 2) 75 mm Hg
 - 3) 30 mm Hg
 - 4) 50 mm Hg
111. At which latitude, heat gain through insolation approximately equals heat loss through terrestrial radiation ?
- 1) 66° North and South
 - 2) 22(1/2)° North and South
 - 3) 40° North and South
 - 4) 42(1/2)° North and South
112. A man and a woman, who do not show any apparent signs of a certain inherited disease, have seven children (2 daughters and 5 sons). Three of the sons suffer from the given disease but none of the daughters are affected. Which of the following mode of inheritance do you suggest for this disease ?
- 1) Autosomal dominant
 - 2) Sex-linked dominant
 - 3) Sex-limited recessive

4) Sex-linked recessive

113. In Ornithine cycle, which of the following wastes are removed from the blood ?

- 1) Urea and urine
- 2) Ammonia and urea
- 3) CO₂ and ammonia
- 4) CO₂ and urea

114. Telomerase is an enzyme which is a :

- 1) repetitive DNA
- 2) RNA
- 3) simple protein
- 4) ribonucleoprotein

115. During transcription holoenzyme RNA polymerase binds to a DNA sequence and the DNA assumes a saddle like structure at that point. What is that sequence called ?

- 1) CAAT box
- 2) GGTT box
- 3) AAAT box
- 4) TATA box

116. Centromere is required for :

- 1) transcription
- 2) crossing over
- 3) cytoplasmic cleavage
- 4) movement of chromosomes towards poles

117. Damage to thymus in a child may lead to :

- 1) a reduction in haemoglobin content of blood
- 2) a reduction in stem cell production
- 3) loss of antibody mediated immunity
- 4) loss of cell mediated immunity

118. Prolonged liberal irrigation of agricultural fields is likely to create the problem of :

- 1) acidity
- 2) aridity
- 3) metal toxicity
- 4) salinity

119. Chlorophyll in chloroplasts is located in :

- 1) grana
- 2) pyrenoid

- 3) stroma
- 4) both (1) and (3)

120. Three crops that contribute maximum to global food grain production are :

- 1) wheat, rice and maize
- 2) wheat, maize and sorghum
- 3) rice, maize and sorghum
- 4) wheat, rice and barley

121. Genes for cytoplasmic male sterility in plants are generally located in :

- 1) mitochondrial genome
- 2) cytosol
- 3) chloroplast genome
- 4) nuclear genome

122. Which one of the following hydrolyses internal phosphodiester bonds in a polynucleotide chain ?

- 1) Lipase
- 2) Exonuclease
- 3) Endonuclease
- 4) Protease

123. Match items in column-I with those in column-II.

	Column-I		Column-II
A	Peritrichous flagellation	1	Ginkgo
B	Living fossil	2	Macrocystes
C	Rhizophore	3	Escherichia coli
D	Smallest flowering plant	4	Selaginella
E	Largest perennial alga	5	Wolffia

Select the correct answer from the following :

Codes :

- 1) A-2, B-1, C-3, D-4, E-5
- 2) A-5, B-3, C-2, D-5, E-1
- 3) A-1, B-2, C-5, D-3, E-2
- 4) A-3, B-1, C-4, D-5, E-2

124. The name of Norman Borlaug is associated with :

- 1) Green revolution
- 2) Yellow revolution
- 3) White revolution
- 4) Blue revolution

125. G-6-P dehydrogenase deficiency is associated with haemolysis of :

- 1) lymphocytes
- 2) RBCs
- 3) platelets
- 4) leucocytes

126. In which one pair both the plants can be vegetatively propagated by leaf pieces ?

- 1) Bryophyllum and Kalanchoe
- 2) Chrysanthemum and Agave
- 3) Agave and Kalanchoe
- 4) Asparagus and Bryophyllum

127. According to IUCN red list what is the status of red Panda (*Ailurus fulgens*) ?

- 1) Vulnerable species
- 2) Critically endangered species
- 3) Extinct species
- 4) Endangered species

128. Which of the following substances, if introduced in the blood stream, would cause coagulation, at the site of its introduction ?

- 1) Fibrinogen
- 2) Prothrombin
- 3) Heparin
- 4) Thromboplastin

129. *E. coli* cells with a mutated Z gene of the lac operon cannot grow in medium containing only lactose as the source of energy because :

- 1) in the presence of glucose, *E. coli* cells do not utilize lactose
- 2) they cannot transport lactose from the medium into the cell
- 3) the lac operon is constitutively active in these cells
- 4) they cannot synthesize functional β -galactosidase

130. Top-shaped multiciliate male gametes and the mature seed which bears only one embryo with two cotyledons, are characteristic features of :

- 1) polypetalous angiosperms
- 2) gamopetalous angiosperms
- 3) conifers
- 4) cycads

131. Production of a human protein in bacteria by genetic engineering is possible because :

- 1) bacterial cell can carry out the RNA splicing reactions
- 2) the human chromosome can replicate in bacterial cell
- 3) the mechanism of gene regulation is identical in humans and bacteria

4) the genetic code is universal

132. From the following statements select the wrong one :

- 1) millepedes have two pairs of appendages in each segment of the body
- 2) prawn has two pairs of antennae
- 3) animals belonging to phylum-Porifera are exclusively marine
- 4) nematocysts are characteristic of the phylum - Cnidaria

133. Nucleotide are building blocks of nucleic acids, nucleotide is a composite molecule formed by :

- 1) (base-sugar-phosphate)_n
- 2) base-sugar-OH
- 3) base-sugar-phosphate
- 4) sugar-phosphate

134. More than 70% of world's freshwater is contained in :

- 1) Antarctica
- 2) Glaciers and Mountains
- 3) Greenland
- 4) Polar ice

135. Which one of the following pairs is mismatched ?

- 1) Biomass burning — release of CO₂
- 2) Fossil fuel burning — release of CO₂
- 3) Nuclear power — radioactive wastes
- 4) Solar energy — green house effect

136. Which one of the following characters is not typical of the class-mammalia ?

- 1) Seven cervical vertebrae
- 2) Thecodont dentition
- 3) Ten pairs of cranial nerves
- 4) Alveolar lungs

137. Which of the following is the simplest amino acid ?

- 1) Tyrosine
- 2) Asparagine
- 3) Glycine
- 4) Alanine

138. Barophilic prokaryotes :

- 1) grow slowly in highly alkaline frozen lakes at high altitudes
- 2) occur in water containing high concentrations of barium hydroxide

- 3) grow and multiply in very deep marine sediments
- 4) readily grown and divides in sea water enriched in any soluble salt of barium

139. Auxospores and hormocysts are formed, respectively, by :

- 1) several diatoms and a few cyanobacteria
- 2) several cyanobacteria and several diatoms
- 3) some diatoms and several cyanobacteria
- 4) some cyanobacteria and many diatoms

140. Enzymes, vitamins and hormones can be classified into a single category of biological chemicals, because all of these :

- 1) enhance oxidative metabolism
- 2) are conjugated proteins
- 3) are exclusively synthesized in the body of a living organism as at present
- 4) help in regulating metabolism

141. Which one of the following phenomena supports Darwin's concept of natural selection in organic evolution ?

- 1) Development of transgenic animals
- 2) Production of 'Dolly' the sheep by cloning
- 3) Prevalence of pesticide resistant insects
- 4) Development of organs from 'stem cells' for organ transplantation

142. As compared to a C₃ plant, how many additional molecules of ATP are needed for net production of one molecule of hexose sugar by C₄ plants :

- 1) 2
- 2) 6
- 3) 0
- 4) 12

143. In a man, abducens nerve is injured. Which one of the following functions will be affected ?

- 1) Movement of the eye ball
- 2) Swallowing
- 3) Movement of the tongue
- 4) Movement of the neck

144. An important step in the manufacture of pulp for paper industry from the woody tissues of plants is the :

- 1) preparation of pure cellulose by removing lignin
- 2) removal of oils present in the wood by treatment with suitable chemicals
- 3) removal of water from the wood by prolonged heating at approximately 50°C
- 4) treatment of wood with chemical that breakdown cellulose

145. Protein synthesis in an animal cell occurs :

- 1) only on the ribosomes present in cytosol
- 2) on ribosomes present in cytoplasm as well as in mitochondria
- 3) only on ribosomes attached to the nuclear envelope and endoplasmic reticulum
- 4) on ribosomes present in the nucleolus as well as in cytoplasm

146. Which of the following is not true for a species ?

- 1) Members of a species can interbreed
- 2) Variations occurs among members of a species
- 3) Each species is reproductively isolated from every other species
- 4) Gene flow does not occur between the populations of a species

147. One of the most important functions of botanical gardens is that :

- 1) one can observe tropical plants there
- 2) they allow ex situ conservation of germplasm
- 3) they provide the natural habitat for wild life
- 4) they provide a beautiful area for recreation

148. The ability of the venus flytrap to capture insects is due to :

- 1) chemical stimulation by the prey
- 2) a passive process requiring no special ability on the part of the plant
- 3) specialized "muscle-like" cells
- 4) rapid turgor pressure changes

149. Animals have the innate ability to escape from predation. Examples for the same are given below. Select the incorrect example :

- 1) enlargement of body size by swallowing air in puffer fish
- 2) melanism in moths
- 3) poison fangs in snakes
- 4) colour change in chameleon

150. At a particular locus, frequency of 'A' allele is 0.6 and that of 'a' is 0.4. What would be the frequency of heterozygotes in a random mating population at equilibrium ?

- 1) 0.16 2) 0.48 3) 0.36 4) 0.24

151. Which one of the following experiments suggests that simplest living organisms could not have originated spontaneously from non-living matter ?

- 1) Microbes did not appear in stored meat
- 2) Larvae could appear in decaying organic matter
- 3) Microbes appeared from unsterilized organic matter
- 4) Meat was not spoiled, when heated and kept sealed in a vessel

152. Biodiversity act of India was passed by the Parliament in the year :

1) 1996

2) 1992

3) 2002

4) 2000

153. During which stage in the complete oxidation of glucose are the greatest number of ATP molecules formed from ADP ?

- 1) Conversion of pyruvic acid to acetyl Co-A
- 2) Electron transport chain
- 3) Glycolysis
- 4) Krebs cycle

154. A woman with normal vision, but whose father was colour blind, marries a colourblind man. Suppose that the fourth child of this couple was a boy. This boy :

- 1) must have normal colour vision
- 2) will be partially colourblind since he is heterozygous for the colourblind mutant allele
- 3) must be colourblind
- 4) may be colourblind or may be of normal vision

155. Ectophloic siphonostele is found in :

- 1) Adiantum and Cucurbitaceae
- 2) Osmunda and Equisetum
- 3) Marsilea and Botrychium
- 4) Dicksonia and maiden hair fern

156. Which of the following represents the edible part of the fruit of litchi ?

- 1) Pericarp
- 2) Mesocarp
- 3) Juicy aril
- 4) Endocarp

157. Carbohydrates, the most abundant biomolecules on earth, are produced by :

- 1) all bacteria, fungi and algae
- 2) fungi, algae and green plant cells
- 3) some bacteria, algae and green plant cells
- 4) viruses, fungi and bacteria

158. Identify the correctly matched pair :

- 1) Montreal protocol - Global warming
- 2) Kyoto protocol - Climatic change
- 3) Ramsar convention - Ground water pollution
- 4) Basal convention - Biodiversity conservation

159. Which of the following is not a hereditary disease ?

- 1) Cretinism

- 2) Cystic fibrosis
- 3) Thalassaemia
- 4) Haemophilia

160. The deficiencies of micro-nutrients, not only affects growth of plants but also vital functions such as photosynthetic and mitochondrial electron flow. Among the list given below, which group of three elements shall affect most, both photosynthetic and mitochondrial electron transport ?

- 1) Cu, Mn, Fe
- 2) Co, Ni, Mo
- 3) Mn, Co, Ca
- 4) Ca, X, Na

161. de Vries gave his mutation theory on organic evolution while working on :

- 1) *Althea rosea*
- 2) *Drosophila melanogaster*
- 3) *Oenothera lamarckiana*
- 4) *Pisum sativum*

162. One of the examples of the action of the autonomous nervous system is :

- 1) knee-jerk response
- 2) pupillary reflex
- 3) swallowing of food
- 4) peristalsis of the intestines

163. Which of the following is not used for disinfection of drinking water ?

- 1) Phenyl
- 2) Chloramine
- 3) Chlorine
- 4) Ozone

164. Chemiosmotic theory of ATP synthesis in the chloroplasts and mitochondria is based on :

- 1) proton gradient
- 2) accumulation of K ions
- 3) accumulation of Na ions
- 4) membrane potential

165. Parkinson's disease (characterized by tremors and progressive rigidity of limbs) is caused by degeneration of brain neurons that are involved in movement control and make use of neurotransmitter :

- 1) acetylcholine
- 2) norepinephrine
- 3) dopamine

4) GABA

166. All of the following statements concerning the actinomycetous filamentous soil bacterium Frankia are correct except that Frankia :

- 1) can induce root nodules on many plant species
- 2) can fix nitrogen in the free-living state
- 3) like Rhizobium, it usually infects its host plant through root hair deformation and stimulates cell proliferation in the host's cortex
- 4) forms specialized vesicles in which the nitrogenase is protected from oxygen by a chemical barrier involving triterpene hopanoids

167. An acromian process is characteristically found in the :

- 1) pelvic girdle of mammals
- 2) skull of frog
- 3) pectoral girdle of mammals
- 4) sperm of mammals

168. In a type of apomixis known as adventive embryony, embryos develop directly from the :

- 1) nucellus or integuments
- 2) synergids or antipodals in an embryo sac
- 3) accessory embryo sacs in the ovule
- 4) zygote

169. Through which cell of the embryo sac, does the pollen tube enter the embryo sac ?

- 1) Egg cell
- 2) Central cell
- 3) Persistent synergid
- 4) Degenerated synergid

170. Epithelial cells of the intestine involved in food absorption have on their surface :

- 1) pinocytic vesicles
- 2) phagocytic vesicles
- 3) zymogen granules
- 4) micro-villi

171. A patient is generally advised to specially, consume more meat, lentils, milk and eggs in diet only when he suffers from :

- 1) kwashiorkor
- 2) rickets
- 3) anaemia
- 4) scurvy

172. Which one of the following pairs is mismatched ?
- 1) Savanna — Acacia trees
 - 2) Prairie — epiphytes
 - 3) Tundra — permafrost
 - 4) Coniferous forest — evergreen trees
173. Which of the following is the relatively most accurate method for dating of fossils ?
- 1) Potassium - argon method
 - 2) Uranium- lead method
 - 3) Electron - spin resonance method
 - 4) Radio - carbon method
174. Which one of the following represents an ovule, where the embryo sac becomes horse-shoe shaped and the funiculus and micropyle are close to each other ?
- 1) Circinotropous
 - 2) Anatropous
 - 3) Amphitropous
 - 4) Atropous
175. Potometer works on the principle of :
- 1) amount of water absorbed equals the amount transpired
 - 2) osmotic pressure
 - 3) root pressure
 - 4) potential difference between the tip of the tube and that of the plant
176. In a woody dicotyledonous tree, which of the following parts will mainly consist of primary tissues ?
- 1) Stem and root
 - 2) All parts
 - 3) Shoot tips and root tips
 - 4) Flowers, fruits and leaves
177. Which one of the following makes use of RNA as a template to synthesize DNA ?
- 1) Reverse transcriptase
 - 2) DNA dependant RNA polymerase
 - 3) DNA polymerase
 - 4) RNA polymerase
178. In contrast to annelids the platyhelminths show :
- 1) radial symmetry
 - 2) presence of pseudocoel
 - 3) bilateral symmetry

4) absence of body cavity

179. Which of the following statements regarding enzyme inhibition is correct ?

- 1) Non-competitive inhibition of an enzyme can be overcome by adding large amount of substrate
- 2) Competitive inhibition is seen when a substrate competes with an enzyme for binding to an inhibitor protein
- 3) Competitive inhibition is seen when the substrate and the inhibitor compete
- 4) Non-competitive inhibitors often bind to the enzyme irreversibly

180. Which of the following pairs is correctly matched ?

- 1) Cartilaginous joint — skull bones
- 2) Hinge joint — between vertebrae
- 3) Fibrous joint — between phalanges
- 4) Gliding joint — between zygapophyses of the successive vertebrae

181. The catalytic efficiency of two different enzymes can be compared by the :

- 1) the K_m value
- 2) the pH optimum value
- 3) formation of the product
- 4) molecular size of the enzyme

182. Using imprints from a plate with complete medium and carrying bacterial colonies, you can select streptomycin resistant mutants and prove that such mutations do not originate as adaptation. These imprints need to be used :

- 1) only on plates with streptomycin
- 2) on plates with minimal medium
- 3) only on plates without streptomycin
- 4) on plates with and without streptomycin

183. Which of the following is generally used for induced mutagenesis in crop plants ?

- 1) Alpha particles
- 2) X-rays
- 3) UV (260 nm)
- 4) Gamma rays (from cobalt 60)

184. Haemophilia is more commonly seen in human males than in human females because :

- 1) this disease is due to an X-linked dominant mutation
- 2) a greater proportion of girls die in infancy
- 3) this disease is due to an X-linked recessive mutation
- 4) this disease is due to a Y-linked recessive mutation

185. A woman with 47 chromosomes due to three copies of chromosome 21 is characterized by :
- 1) Down syndrome
 - 2) triploidy
 - 3) Turner syndrome
 - 4) super femaleness
186. In order to find out the different types of gametes produced by a pea plant having the genotype AaBb, it should be crossed to a plant with the genotype
- 1) aaBB
 - 2) AaBB
 - 3) AABB
 - 4) aabb
187. Four healthy people in their twenties got involved in injuries resulting in damage and death of a few cells of the following. Which of the cells are least likely to be replaced by new cells ?
- 1) Osteocytes
 - 2) Malpighian layer of the skin
 - 3) Liver cells
 - 4) Neurons
188. Secretin and cholecystokinin are digestive hormones. They are secreted in :
- 1) oesophagus
 - 2) ileum
 - 3) duodenum
 - 4) pyloric stomach
189. Which of the following unicellular organism has a macro-nucleus for trophic function and one or more micro-nuclei for reproduction ?
- 1) Euglena
 - 2) Amoeba
 - 3) Paramecium
 - 4) Trypanosoma
190. AIDS is caused by HIV that principally infects :
- 1) all lymphocytes
 - 2) activator B cells
 - 3) T 4 lymphocytes
 - 4) cytotoxic T cells
191. According to widely accepted "fluid mosaic model" cell membranes are semi-fluid, where lipids and integral proteins can diffuse randomly. In recent years, this model has been modified in several respects. In this regard, which of the following statements is incorrect?
- 1) Proteins in cell membranes can travel within the lipid bilayer
 - 2) Proteins can remain confined within certain domains of the membrane

- 3) Proteins can also undergo flip-flop movements in the lipid bilayer
4) Many proteins remain completely embedded within the lipid bilayer
192. If mammalian ovum fails to get fertilized, which one of the following is unlikely ?
1) Corpus luteum will disintegrate
2) Estrogen secretion further decreases
3) Primary follicle starts developing
4) Progesterone secretion rapidly declines
193. A person is undergoing prolonged fasting. His urine will be found to contain abnormal quantities of :
1) fats
2) ketones
3) amino acids
4) glucose
194. Why is vivipary an undesirable character for annual crop plants ?
1) It reduces the vigour of plant
2) The seeds cannot be stored under normal conditions for the next season
3) The seeds exhibit long dormancy
4) It adversely affects the fertility of the plant
195. *Bacillus thuringiensis* (Bt) strains have been used for designing novel :
1) bio-metallurgical technique
2) bio-mineralization processes
3) bio-insecticidal plants
4) bio-fertilizers
196. The salivary gland chromosomes in the dipteran larvae, are useful in gene mapping because :
1) these are much longer in size
2) these are easy to stain
3) these are fused
4) they have endoreduplicated chromosomes
197. Which group of three of the following five statements (1-5) contain all three correct statements regarding beri-beri ?
A. A crippling disease prevalent among the native population of sub-Saharan Africa.
B. A deficiency disease caused by lack of thiamine (vitamin B₁).
C. A nutritional disorder in infants and young children when the diet is persistently deficient in essential protein.
D. Occurs in those countries where the staple diet is polished rice.
E. The symptoms are pain from neuritis, paralysis, muscle wasting, progressive oedema, mental deterioration and finally heart failure.
-

mental deterioration and finally heart failure.

- 1) A, B and D
- 2) B, C and E
- 3) A, C and E
- 4) B, D and E

198. Photosynthetic Active Radiation (PAR) has the following range of wavelengths :

- 1) 400 - 700 nm
- 2) 450 - 950 nm
- 3) 340 - 450 nm
- 4) 500 - 600 nm

199. Golden rice is a transgenic crop of the future with the following improved trait :

- 1) high lysine (essential amino acid) content
- 2) insect resistance
- 3) high protein content
- 4) high vitamin A content

200. Which one of the following depresses brain activity and produces feelings of calmness, relaxation and drowsiness.

- 1) Valium
- 2) Morphine
- 3) Hashish
- 4) Amphetamines

Answer Key

1) 3	2) 3	3) 1	4) 2	5) 1	6) 1	7) 2	8) 2	9) 2	10) 4
11) 2	12) 3	13) 1	14) 1	15) 1	16) 2	17) 4	18) 4	19) 1	20) 4
21) 3	22) 4	23) 2	24) 1	25) 4	26) 1	27) 1	28) 3	29) 3	30) 3
31) 2	32) 3	33) 3	34) 3	35) 4	36) 2	37) 1	38) 1	39) 3	40) 2
41) 4	42) 4	43) 3	44) 4	45) 4	46) 4	47) 4	48) 4	49) 2	50) 2
51) 2	52) 3	53) 4	54) 4	55) 4	56) 3	57) 4	58) 1	59) 3	60) 2
61) 4	62) 4	63) 1	64) 4	65) 2	66) 2	67) 1	68) 3	69) 4	70) 3
71) 4	72) 1	73) 4	74) 1	75) 1	76) 1	77) 1	78) 2	79) 3	80) 4
81) 3	82) 1	83) 2	84) 4	85) 4	86) 2	87) 3	88) 1	89) 1	90) 3
91) 2	92) 4	93) 1	94) 1	95) 4	96) 2	97) 4	98) 3	99) 4	100) 3
101) 2	102) 3	103) 2	104) 2	105) 2	106) 3	107) 2	108) 4	109) 3	110) 1
111) 3	112) 4	113) 3	114) 4	115) 4	116) 4	117) 4	118) 4	119) 1	120) 1
121) 1	122) 3	123) 4	124) 1	125) 2	126) 1	127) 4	128) 4	129) 4	130) 4
131) 4	132) 2	133) 3	134) 4	135) 4	136) 3	137) 3	138) 3	139) 1	140) 4
141) 3	142) 4	143) 1	144) 1	145) 2	146) 4	147) 2	148) 4	149) 3	150) 2
151) 4	152) 3	153) 2	154) 4	155) 2	156) 3	157) 3	158) 2	159) 1	160) 1
161) 3	162) 4	163) 1	164) 1	165) 3	166) 2	167) 3	168) 1	169) 4	170) 4
171) 1	172) 2	173) 3	174) 3	175) 1	176) 3	177) 1	178) 4	179) 3	180) 4
181) 1	182) 1	183) 4	184) 3	185) 1	186) 4	187) 4	188) 3	189) 3	190) 3
191) 3	192) 2	193) 2	194) 2	195) 3	196) 4	197) 4	198) 1	199) 4	200) 1